

شرکت طها تجارت کامران  
www.TahaTk.com  
۰۲۱-۲۸۴۲۵۳۶۳



**DEMAG**  
Cranes & Components

## Demag Standard Cranes

Performance and efficiency at the highest level



# Demag sets crane standards for the future

Standard solutions made by Demag offer outstanding quality, efficiency, and reliability at the highest level. Every crane and every crane component reflects decades of crane expertise and reliability as a partner for the industry.

## Innovation for greater efficiency to benefit our customers

With the new DR rope hoist, Demag Cranes & Components has introduced a state-of-the-art standard for crane applications with loads weighing up to 50 mt and, at the same time, an entirely new crane philosophy.

The C shape of the Demag DR rope hoist design is ideally suited to crane applications. Thanks to the many benefits offered by the new DR rope hoist, the entire crane operates much more efficiently.

- Proven crane geometry guarantees high design rigidity, optimum travel characteristics and minimum wear
- Raised crane girders, designs tailored to match the roof structure, and compact trolleys with minimum approach dimensions facilitate larger hook paths as well as better utilization of the available space and reduce initial construction and subsequent costs
- Ergonomic pushbutton stations and interactive radio controls with load range display ensure highly convenient operation and safe load handling. The display provides complete transparency of the system controls



38926-2

- Infinitely variable speed control in all motion axes, via frequency inverter-fed drives, reduces load sway, facilitates exact and gentle positioning, and lowers the mechanical load on the crane installation
- High lifting and cross travel speeds provide faster handling rates and greater efficiency
- Standard overload devices prevent unsafe overload conditions

Crane type	Under running single girder cranes	Top running single girder cranes	Top running double girder cranes
Capacity* up to	10 mt	12.5 mt	50 mt
Span* up to	60' (18m)	98' (30m)	
Bridge travel speed* up to	160 fpm		
Trolley travel speeds* up to	100 fpm	82 fpm	
Hoist lifting speed* up to	41 fpm		
Stepless motions	3 axes		

\* Other specifications on request



39343-2

Infinitely variable speed control facilitates particularly gentle handling of the load

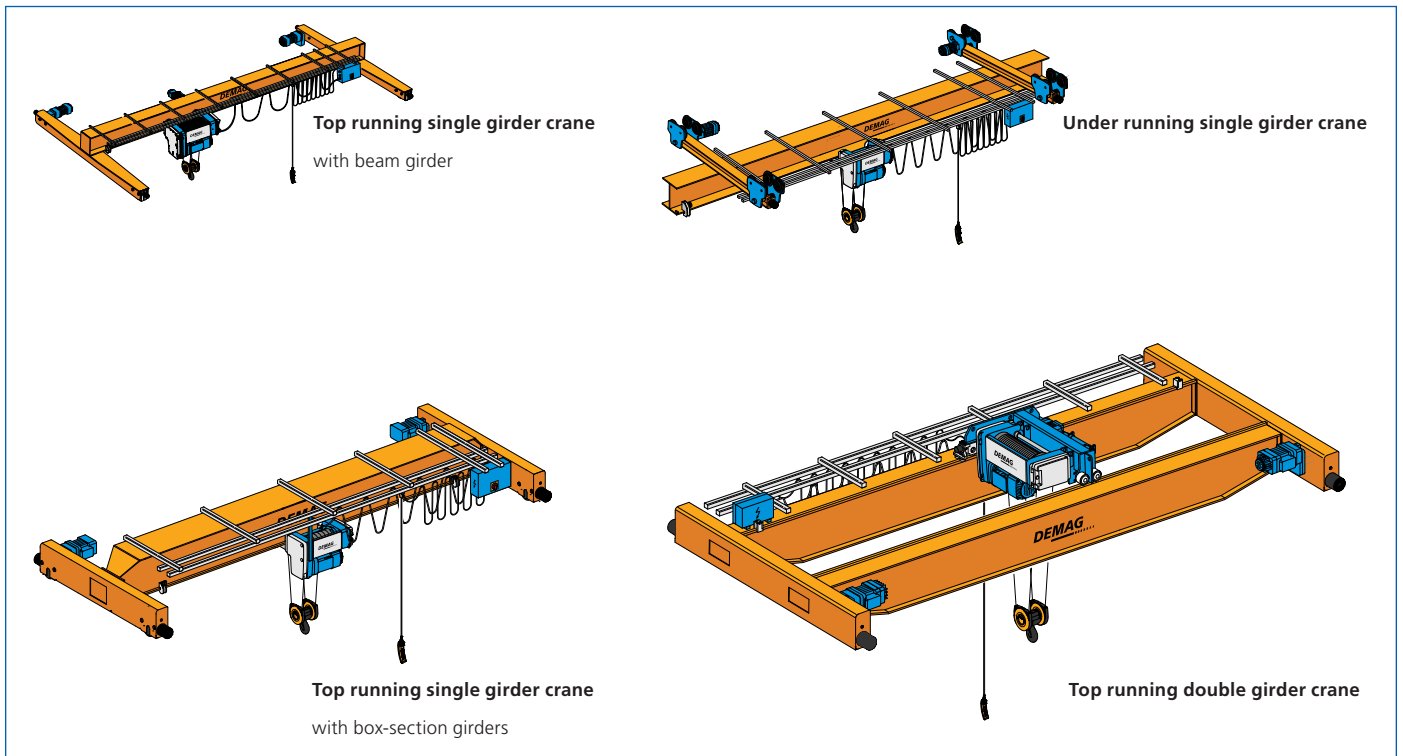



# Attention to detail for total quality



## End truck

- Maximum strength by using a rigid box-section design with reinforced connection areas as well as machined tolerances in the crane girder connection system guarantee superior structural integrity and optimum travel characteristics with minimum wear
- The precise travel wheel alignment and exact adaptation of the crane span dimension via interchangeable spacer elements ensure optimum travel characteristics and high adaptability
- End trucks configured with proprietary structural design programs

## Travel unit

- Maintenance-free drives with anti-friction bearings lubricated for life, maximum bearing centers to accommodate horizontal forces, and travel wheels made of spheroidal graphite nodular iron provide for favorable travel characteristics and minimum crane runway wear
- Infinitely stepless variable travel speeds via frequency inverters with speeds up to 240 fpm guarantee travel with minimum load-sway as well as precise positioning



## Power supply line

- Demag DCL compact conductor line for 4 to 7 poles; connections ensure long-term power supply and minimize unplanned downtime
- Pre-assembled building blocks for simple assembly or replacement of current collector trolleys or complete straight sections provide optimum serviceability
- IP 23 or IP 24 high protection against accidental contact with sealing lip and integral expansion joints for optimum safety

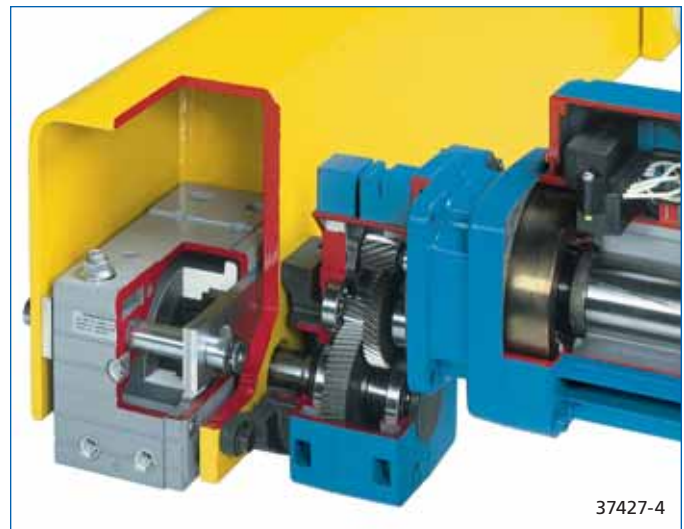

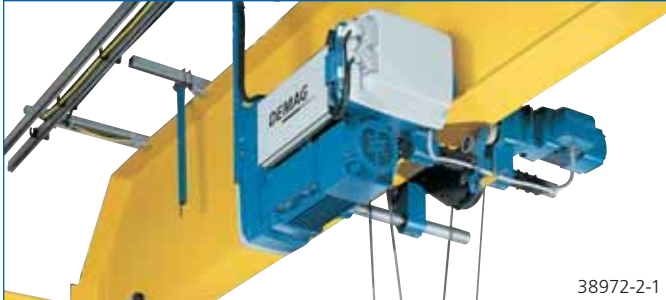

### Hoist trolleys

- State-of-the-art Demag DR rope hoist of C-shaped design optimized for crane applications with higher hoist and cross travel speeds provides higher handling rates and efficiency for cranes with capacities up to 50 m t
- Compact designs with minimum approach dimensions and larger hook path guarantee optimum utilization of the available space and height and reduce initial construction and subsequent costs
- Infinitely variable hoist and travel motions guarantee low-sway handling. Precise, gentle positioning provides for greater safety and convenient operation
- CAN Bus technology to meet tomorrow's demands for high data transmission reliability, corresponding to safety class 3 to DIN/EN 954, ensures optimum monitoring for greater efficiency thanks to preventive maintenance

### Bottom block

- Enhanced bottom block design with standard load hook for ease of load connection
- Rope lead-in guard eliminates the risk of being caught between the rope and sheave
- Handle recesses on both sides simplify handling of the bottom block and increase operating safety



### Control system

- Ergonomically designed control units for safe, fatigue-free handling. The display provides complete transparency for control of the installation. The CAN Bus control system corresponds to safety category 3 to DIN/EN 954.
- Demag DSE pushbutton control pendant suspended for separate travel on the crane girder
  - Handheld or belly box CAN Bus radios for wireless control allow operator flexibility



# Top running single girder cranes

EKKE top running single girder cranes provide you with Demag technology at a particularly attractive price. They feature maximum rigidity for a minimum deadweight. This keeps the load on the crane runway low, and a cost-effective design can be selected for the building. They also offer the benefits of outstanding crane geometry, resulting in exceptional travel characteristics. The Demag EKDR rope hoist is the optimum design for crane applications, enabling the crane to meet your requirements for greater efficiency.

## Benefits and features

- Computer-optimized box section for the crane girder
- End truck of torsionally rigid, welded box girder construction
- Travel wheels of highly wear-resistant GGG 70 spheroidal nodular iron with self-lubricating properties

- Connections between the girder and end trucks manufactured to precise machined tolerances for minimum wear
- Trolley of low-headroom design with rope hoist, offering particularly favorable hook approach dimensions to serve the largest possible area
- Power supply to the trolley via high-flexibility flat cable with protective ground conductor
- Control pendant suspended for separate travel on the crane girder, with display for system monitoring
- Optional: radio remote control
- Pre-treatment of steel components for optimum anti-corrosion protection of all parts
- Paint finish in golden yellow. Travel drives in azure blue. Trolley powder-coated in azure blue and silver grey

## EKKE single girder crane

Technical data	
Capacity	to 12.5 mt
Span	to 98'
Bridge travel speed	to 160 fpm
Trolley travel speed	to 100 fpm
Hoist speed	to 41 fpm

Other specifications on request

## Options

See accessories, page 14

## Technical data sheet

Ident. no. 900 435 49

## Optimum adaptation to the building design

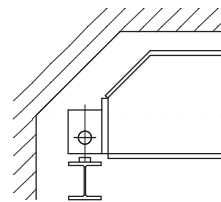

Type 1

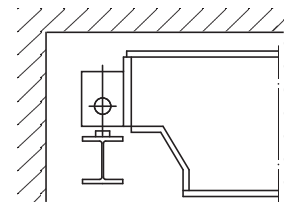

Type 2

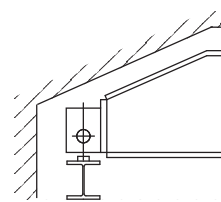

Type 3

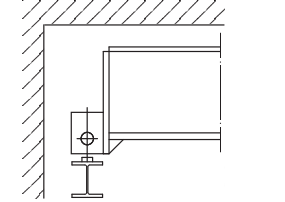

Type 4/5



**Your benefits with the Demag DR rope hoist optimized for crane applications**

- Minimum operating cost thanks to extended FEM 2m+ service life (1900-hour full load service life) which exceeds the duty requirements of H4 rating per ASTM B30.16
- Improved load handling due to increased lifting and cross travel speed
- Minimum load-sway thanks to infinitely variable cross travel speeds
- System monitoring for improved operational transparency
- Improved utilization of your production area thanks to minimum approach dimensions

# Top running single girder cranes with beam girder

EKKE top running single girder cranes with beam girders offer outstanding value for the money. The use of rolled steel sections for the crane girder and traveling rope hoists optimized for crane applications make these cranes the optimum solution for lighter loads and shorter spans.

EKKE standard cranes ensure efficient and fatigue-free load handling thanks to the higher cross travel speed and optimized ergonomic control pendants. When fitted with features such as infinitely variable speed cross travel drives, they also make it possible to achieve low-sway travel motions for gentle handling and precise positioning of loads.

In addition, they also offer high reliability and safety as well as a long service life combined with high levels of operating efficiency by all components.

## Benefits and features

- Rolled section crane girder
- Optimum adaptation to the building design (page 6)

## EKKE single girder crane

Technical data	
Capacity	to 10 mt
Span	to 59'
Bridge travel speed	to 160 fpm
Trolley travel speed	to 100 fpm
Hoist speed	to 41 fpm

Other specifications on request

## Options

See accessories, page 14

## Technical data sheet

Ident. no. 900 435 49



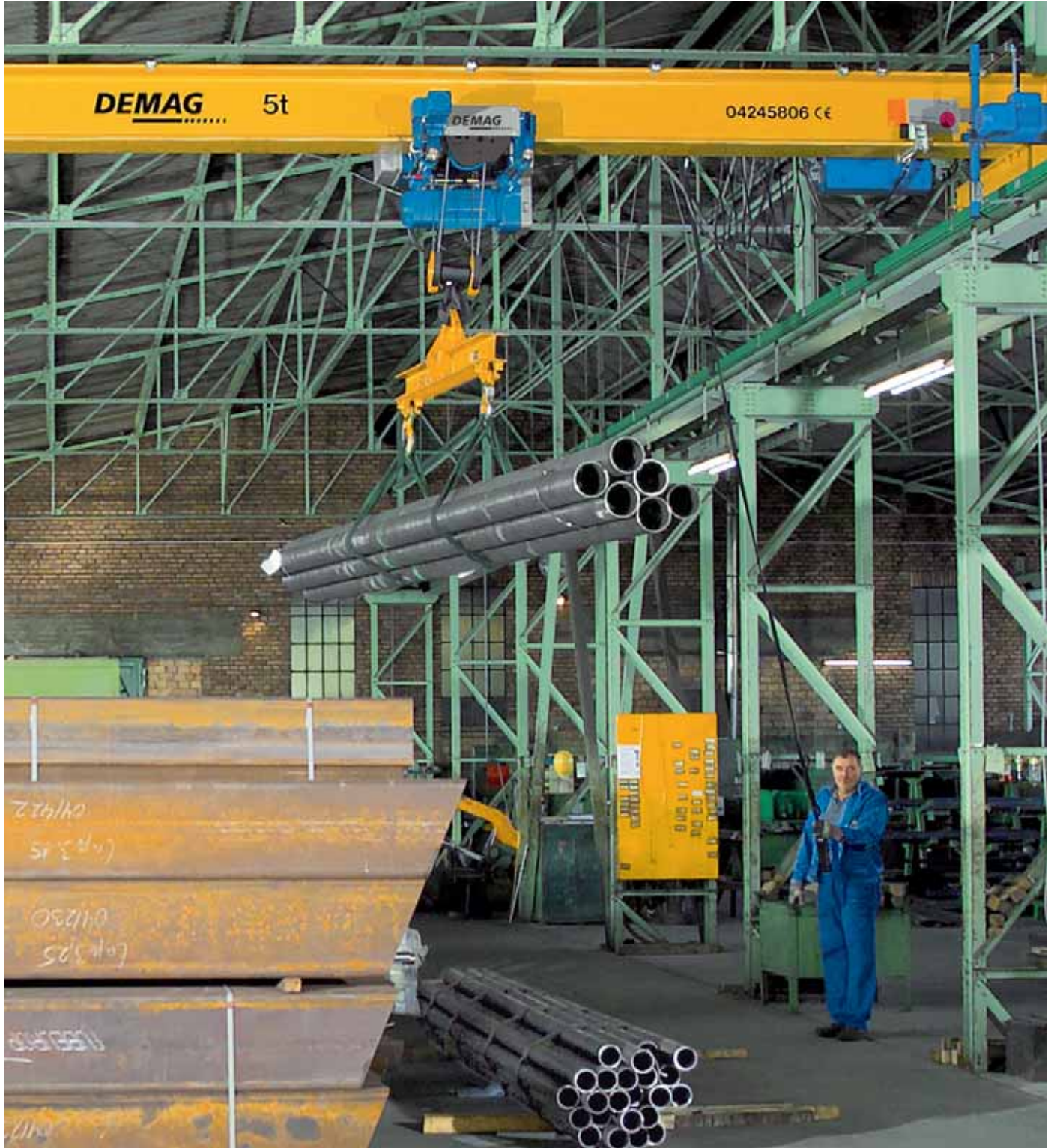

The standard display in the control pendant provides complete transparency for control of the crane system

# Under running single girder cranes – the column-free alternative

Simply attached to the existing roof structure, Demag under running cranes eliminate the need for runway support columns. This way, the entire building floor area is available for production. Peripheral areas of the workshop can be served by using the girder overhangs to extend the travel range of the hoist trolley beyond the runways. Optional latching devices make it possible to transfer the hoist trolley from the crane girder to a branch track and back without having to deposit the load.

## Benefits and features

- Consistent quality with overhead traveling crane benefits
- End truck of optimized structural design
- Rigid beam girders or welded box girders for optimum load distribution
- Loads can be handled immediately adjacent to the building wall by means of girder ends tailored to the application requirements

## EDKE under running single girder crane

Technical data	
Capacity	to 10 mt
Span	to 60'
Bridge travel speed	to 160 fpm
Trolley travel speed	to 100 fpm
Hoist speed	to 41 fpm

Other specifications on request

## Options

See accessories, page 14

## Technical data sheet

Ident. no. 900 436 49





Radio control systems enable cranes to be controlled from any operator position

# Top running double girder overhead cranes – high load capacities combined with long spans

Demag double girder overhead traveling cranes offer you a virtually unmatched deadweight/load capacity ratio. They are also characterized by their outstanding crane geometry, ensuring extremely favorable travel characteristics and therefore minimizing wear. The particularly large lifting height is derived from the fact that the load hook can be raised between the two crane girders. Depending on requirements, our double girder overhead traveling cranes can also be fitted with radio or operator cab controls. Optional maintenance platforms and trolley platforms not only facilitate crane maintenance but also ensure that your hall fittings such as lamps, heating elements or supply lines can be quickly and easily reached.

## Benefits and features

- Consistent quality with overhead traveling crane benefits
- Performance oriented double girder bridge design for high speeds in all axes
- Optimized structural design using proprietary software to meet crane duty class requirements per specified standards
- Low deadweight reduces initial runway structure investment
- Options
  - Maintenance platform
  - Full length walkway on one or both girders
  - Trolley maintenance platform

## ZKKE double girder crane

Technical data	
Capacity	to 50 mt
Span	to 114'
Bridge travel speed	to 160 fpm
Trolley travel speed	to 82 fpm
Hoist speed	to 41 fpm

Other specifications on request

## Options

See accessories, page 14

## Technical data sheet

Ident. no. 900 463 49

## Optimum adaptation to the building design

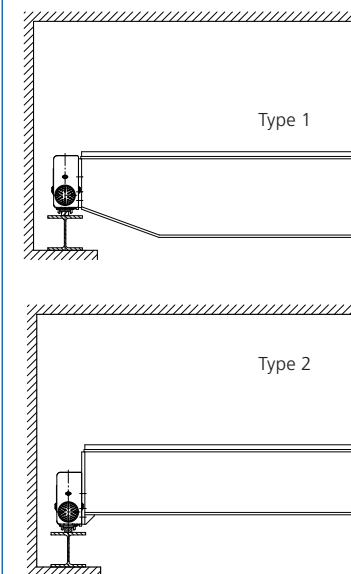





The double girder design provides for particularly high load capacities and sensitive load handling thanks to infinitely variable speed control

## Demag crane accessories and auxiliary equipment

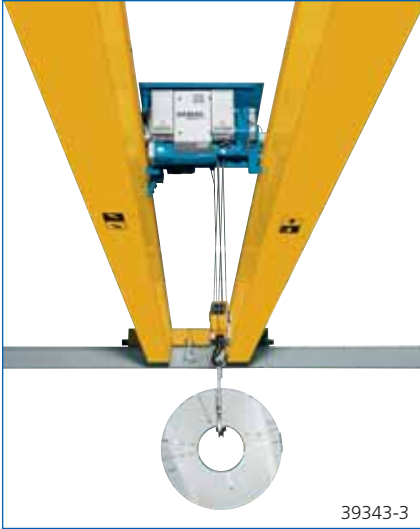

With our wide range of accessories and auxiliary equipment, we are able to adapt our standard cranes to the individual requirements of your application.

- Control by means of a pendant switch or, if desired, interactive radio control
- Variable speed motors with frequency inverters help to avoid load sway
- Cranes equipped with two trolleys make it easy to handle long and awkward loads
- A comprehensive range of load handling attachments satisfies the most varied requirements

- For applications that are not suitable for the digital CAN Bus control technology, Demag offers the flexibility to provide any DR hoist with conventional, non-digital controls

Planners and plant designers can use our online Automated Quotation System (AQS), which allows for quick and easy configuration of standard cranes, complete with dimensional Auto CAD drawings of the cranes.  
<http://aqs.demag-us.com>





Double girder overhead traveling crane with tandem end trucks for transporting and turning engine blocks



Crane system data can be displayed for preventative and scheduled maintenance

## Sales and Service Centers in North America

California 5435 Industrial Parkway • San Bernardino, California 92407  
Telephone (909) 880-8800 • Fax (909) 880-4469

Georgia 254 Lake Ruby Drive • Suwanee, Georgia 30024  
Telephone (678) 546-0593 • Fax (678) 482-7653

Illinois 11261 Kiley Drive • Huntley, Illinois 60142  
Telephone (847) 515-7030 • Fax (847) 515-7040

Michigan 46545 Continental Drive • Chesterfield, Michigan 48047  
Telephone (586) 949-6035 • Fax (586) 949-6038

Missouri 3375 Hwy 185 • Washington, Missouri 63090  
Telephone (314) 401-9517 • Fax (636) 239-4217

South Carolina BTC 560, Suite 150, 454 S. Anderson Road • Rock Hill, SC 29730  
Telephone (803) 909-9000 • Fax (803) 909-9001

Ohio 29201 Aurora Road • Cleveland, Ohio 44139  
Telephone (440) 248-2400 • Fax (440) 248-3874

Ontario 1155 North Service Road West, Unit 1 • Oakville, Ontario L6M 3E3  
Telephone (905) 825-5900 • Fax (905) 825-5901

Quebec 3524, Rue Ashby • St-Laurent, Quebec H4R 2C1  
Telephone (514) 336-5556 • Fax (514) 336-4349

Texas 16430 Aldine-Westfield Road • Houston, Texas 77032  
Telephone (281) 443-7331 • Fax (281) 443-7308

Washington 704 - 228th Avenue NE • Sammamish, Washington 98074  
Telephone (425) 883-4668 • Fax (425) 883-4828

### Demag Cranes & Components Corp.

29201 Aurora Road  
Cleveland, Ohio 44139  
Telephone (440) 248-2400  
Fax (440) 248-3874  
www.demag-us.com

**DEMAG**  
Cranes & Components